

SPARE PARTS SECTION

The following section covers the spare parts diagrams and lists that were current at the time this manual was originally printed. Due to continuous improvements of the machine, changes may be made at any time without notification.

HOW TO ORDER SPARE PARTS

1. Have your machines model number, serial number & date of manufacture on hand, these can be found on the specification plate mounted on the machine
2. A scanned copy of your parts list/diagram with required spare part/s identified
3. Go to www.machineryhouse.com.au/contactus and fill out the enquiry form attaching a copy of scanned parts list.





OPERATION MANUAL

SPARE PARTS

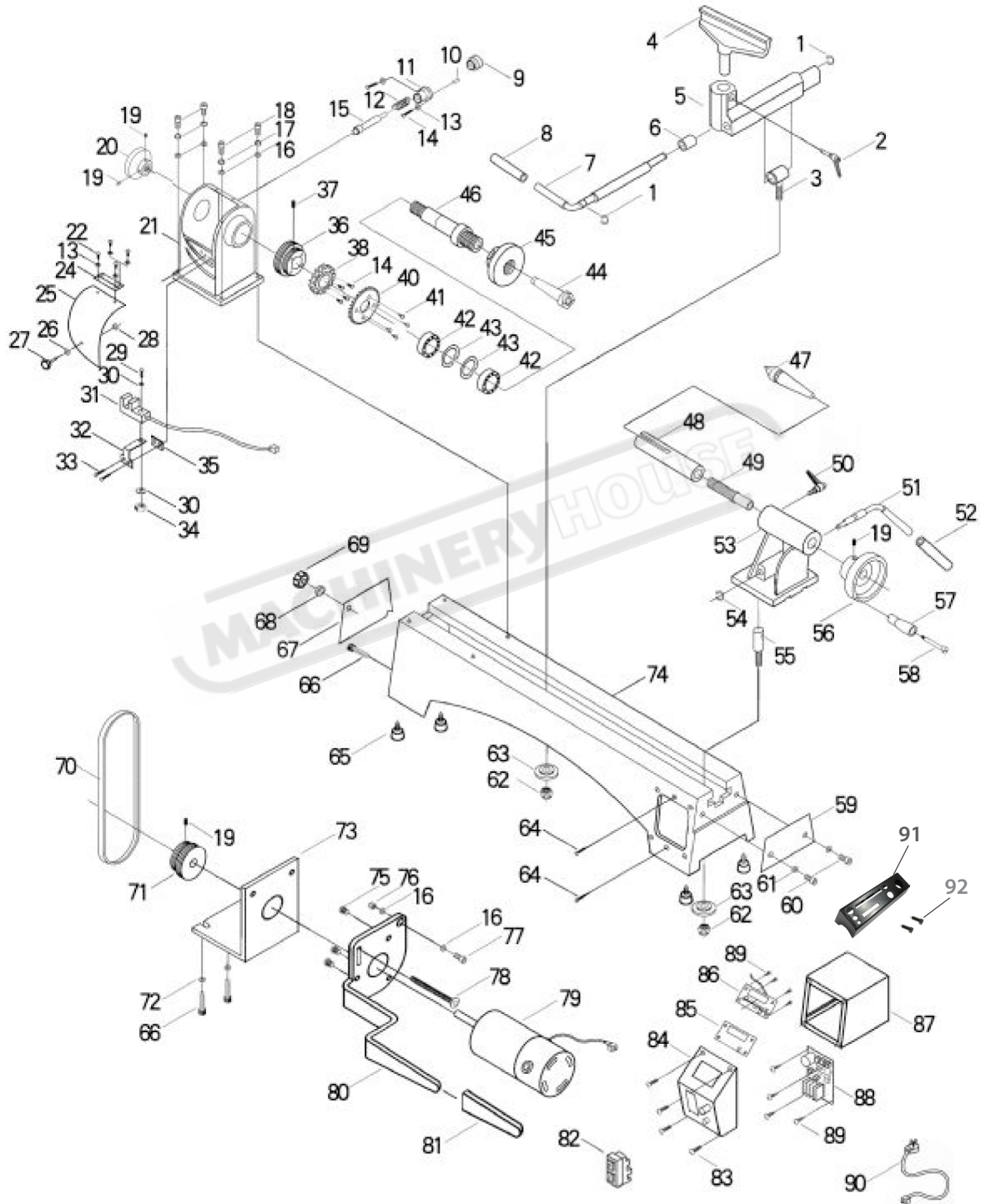

OPERATION MANUAL

SPARE PARTS Cont.

No.	Description	Qty	No.	Description	Qty
1	Retaining ring 12	2	40	Ring gear	1
2	Tool rest lock handle	1	41	Tap screw 4x10	4
3	Tool rest cam follower	1	42	Spindle bearing	2
4	300mm tool rest	1	43	Circlip 47	2
5	Toolslide	1	44	Spur centre	1
6	Tool rest bushing	1	45	Faceplate	1
7	Camshaft handle	1	46	Spindle	1
8	Handle sleeve	1	47	Live centre	1
9	Index pin knob	1	48	Tailstock quill	1
10	Tension pin 4x14	1	49	Tailstock leadscrew	1
11	Index pin housing	1	50	Lock handle	1
12	Spring	1	51	Tailstock lever	1
13	4mm Washer	6	52	Handle sleeve 2	1
14	Pan head screw M4x16	2	53	Tailstock	1
15	Index pin	1	54	Retaining ring 10	1
16	8mm washer	4	55	Cam follower tailstock	1
17	8mm spring washer	4	56	Quill adjusting wheel	1
18	Hex socket screw M8x30	4	57	Quill crank handle	1
19	Hex socket screw M6x12	3	58	Shoulder screw	1
20	Handle wheel	1	59	Retaining plate	1
21	Headstock	1	60	Hex socket screw M10x12	2
22	Pan head screw M4x12	4	61	10mm washer	2
24	Hinge	1	62	M10 locknut	2
25	Headstock guard	1	63	Lock plate	2
26	Washer	1	64	Tap screw 4x20	2
27	Headstock guard lock	1	65	Rubber foot	4
28	E ring 4	1	66	Hex socket screw M5x12	3
29	Pan head screw M3x12	1	67	Fender plate	1
30	3mm washer	2	68	Washer	1
31	Speed sensor	1	69	Motor locking handle	1
32	Insert plate	1	70	Belt	1
33	Sunk screw M4x10	2	71	Motor pulley	1
34	Nut M3	1	72	5mm washer	2
35	Plate	1	73	Fixed plate	1
36	Drive pulley	1	74	Main bed	1
37	Hex screw M6x12	1	75	Sunk screw M6x12	3
38	Spindle index wheel	1	76	M8 locknut	1

OPERATION MANUAL

SPARE PARTS Cont.

No.	Description	Qty	No.	Description	Qty
77	Hex socket screw M8x30	1	84	Control panel	1
78	Carriage bolt M8x120	1	85	Digital display	1
79	Motor	1	86	Display control board	1
80	Belt tension lever	1	87	Controller box	1
81	Motor plate handle sleeve	1	88	Controller board	1
82	Switch	1	89	Tap screw 3x10	8
83	Tap screw 4x24	4	90	Power cord	1
			91	Tool Accessory Rack	1
			92	M8x16mm Sck Hd Cap Scr	2

Wiring Diagram

